

## ANSYS DesignSpace Helps Texas-Based Elevator Manufacturer Reach for New and Higher Standards

CHAMPION ELEVATORS INC.

### EXECUTIVE SUMMARY

#### Challenge:

To re-design cost-effective, yet safe rack-and-pinion elevators that conform to the stringent building and electrical codes of the high-rise construction industry

#### Solution:

Use ANSYS DesignSpace to cut weight and cost on elevator cars while conforming to safety regulations

#### Benefits:

Saved 45 pounds per elevator car

Protected the margins of safety

Allows Champion to work easily with materials, geometry and specifications

#### Introduction

In the heavily regulated world of high-rise construction, rack-and-pinion elevators that move workers, tools and materials to upper stories on a tower must meet two different sets of standards. One set of standards is comprised of building and electrical codes that are essentially regulatory. The other is safety standards that are essentially physical properties.

Located just west of Houston's Hobby Airport, Champion Elevators Inc. is the acknowledged leader in the design and installation of rack-and-pinion driven elevators. Aside from construction, its biggest market, Champion elevators are on offshore oil and gas rigs, refineries and power plants; in port facilities and shipyards and on ships; in or on the outsides of buildings, towers, iron and steel

mills and bridges. Six Champion elevators are on New York City's George Washington Bridge. Champion elevators are also in mines and tunnels.

Champion Elevators' basic design is a tower assembled from standard segments, rigid ties to connect it to the exterior of the structure, electrically powered rack-and-pinion drives, sheet metal elevator cars, automatic braking (in case of power, over speed or safety device failures) and spring-like buffers at the bottoms of the towers. The towers are rectangular tubes with channels and stiffening grids fabricated in five-foot sections. The rack for rack-and-pinion drive is pre-mounted on the tower's exterior.

#### Challenge

After almost three decades in the business, the people at Champion Elevators Inc., Houston, know that conformance to building codes is a must. Given the obvious risks, engineers at Champion run every job through analysis.

Assuring safety and conformance to the codes and regulations fall into two very different types of engineering analyses. Safety assurances of the elevator — essentially measuring maximum stresses and ensuring adequate safety margins — is handled with ANSYS DesignSpace® software for finite element modeling and finite element analysis (FEM/FEA) from ANSYS Inc.



Photo of a Champion Elevator installation during remodeling and expansion of the Texas Children's Hospital building in Houston.

*"We saved 45 pounds of steel per elevator car. While this might seem trivial, those 45 pounds no longer have to be hauled up and down the side of every Champion tower countless times."*

Code and regulatory conformance of the tower is verified with beam modelers designed with specific regulatory codes at their analytical hearts. Sometimes called “stick modelers,” these packages allow for rapid modeling and analysis of the towers.

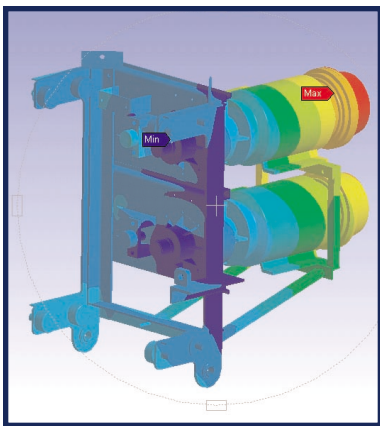

*ANSYS DesignSpace screen image of the redesigned elevator car drives and uncounter-weighted mountings by Champion Elevators. Redesign increased strength and made ride smoother while saving weight.*

Like DesignSpace, beam modelers support finite element modeling and analysis. “Here at Champion, the physical values generated for the codes by the beam modelers are used as input to DesignSpace,” explained Bradley D. Oliver, P.E., Senior Engineer. “We use the deformation information for verifying conformance to codes because that is how codes are expressed,” he noted. “The forces generating those deformations have to be derived for each installation. They are always different.”

The beam package used by Champion does static and dynamic analysis in steel, concrete and composite-materials designs. It can calculate section properties of custom and built-up shapes including area, moments of inertia, section modulus, center of gravity, shear center, and

torsional constants. The package is built around the codes of the American Society of Civil Engineers (ASCE) and is configured to show conformance to specific sections of this most fundamental construction-engineering code.

Without 3-D solid meshing, however, beam modelers cannot generate sufficient data for the stress calculations that lie at the heart of margins of safety. Nor can they be used very effectively for design verification, the task for which ANSYS originally conceived DesignSpace. Champion Elevator runs all its analysis software on a Dell Computer Corp. D-530 workstation with dual Intel Corp. Xeon CPUs totaling 3.8 gigabits of random-access memory (RAM) running at 1.5 gigahertz. Disk drive capacity is 39 gigabytes. Operating systems are Microsoft Corp. Windows 2000 and NT server.

What sets Champion Elevators apart from competitors is its ability to custom engineer unique products. From a manufacturing and operations standpoint, it is a custom fabrication shop. There are no assembly lines. Each product is made to rigid specifications, as determined by the client and its own engineers. The company employs 150.

Champion sees the high-rise construction part of its business as “commercial.” Embracing refurbishing and demolition, these installations are almost always temporary. In most cases, these systems are rented. Champion has one of the industry’s largest such “fleets” of equipment.

Many of the safety challenges of high-rise construction also apply when inside buildings and underground, but the business environment is substantially different. Champion categorizes

these more or less permanent installations as “industrial.”

#### *Codes and Design Refinement\**

In addition to ASCE, the list of regulatory codes to which elevators must conform is long:

- AISC for steel fabrication
- AGMA for rack and pinion drives
- AWS for anything that is welded
- ASTM for anything that is galvanized
- The U.S. National Electrical Code and its international counterpart in Europe
- ANSI for permanent construction and temporary elevators
- UBC for earthquakes

Also, there are countless local building codes that Champion has to verify with the city and county where the system will be installed.

Plus, there is weather with which to contend. “Along the coasts we have to meet hurricane standards,” Oliver pointed out. “We have to determine and verify that our installation will withstand sustained loading, parallel and perpendicular, of winds of 125 miles per hour (MPH) and 150 MPH on Guam. Wind-load details are generated in the beam modeler with ASCE codes.

Added Bob Meiresonne, Engineering Manager: “We analyze every job. Our products may be standardized but the applications always vary. Both code conformance and margins of safety have to be verified,” he added. “Customers doing due diligence often ask for the standardized DesignSpace reports that are generated automatically.

#### **Solution**

“On commercial jobs we usually just do worst-case analyses and provide the customer with

*\*The building code abbreviations are AISC for the American Institute of Steel Construction, AGMA for the American Gear Manufacturers Association, AWS for the American Welding Society, ASTM for the American Society for Testing and Materials and ANSI for the American National Standards Institute. UBC is the Uniform Building Code.*

specific loading criteria for the building ties," Meiresonne added. "Some of these ties are standard but some are specially engineered to the condition of the building's exterior, its age and what is being done to it." For offshore oil rigs and ships, Champion submits its analyses to the American Bureau of Shipping (ABS) or Det Norske Veritas (DNV). Without an okay from one of these industry "classification societies," insurance coverage will be denied.

"The truly interesting thing with DesignSpace is that you can really refine a design," said Meiresonne. "In a particular installation, you can determine where the problems are most likely to be. It will show you where you need to strengthen the design versus just adding steel, which adds weight," he pointed out. "The beam modelers cannot do that."

Analyzing a multitude of points of stress became vital when the company began re-engineering its products in 2000 to reduce weight and cost and simplify manufacturing. "DesignSpace shows you that the stresses are not always where you might think they would be," he added, pointing out that this is why DesignSpace requires specific numerical values and not just standard data from the codes. "In other cases it exposes bad assumptions and keeps you from just throwing metal at a problem. Around here weight is very important."

Oliver elaborated. "Our analysis jobs always start with a mathematical calculation package," he said. "We use the math package to derive the forces for entering into DesignSpace. We do the analysis with the actual numbers taken from the codes. The math package is used because the codes just give us results, specific values that must be met. We have to work backwards to get

the relevant numbers for each part of the code."

The beam modeler lets him create simple models quickly and run them past a solution engine, which compares the design with the relevant codes. The result is a yea or a nay. "This is sufficient for building codes, windstorm resistance, ABS and DNV," Oliver noted. "The beam modeler analyzes our tower design and forces acting on buildings and structures," he continued. "This is non-meshed modeling, but it goes quite far beyond sticks and simple solid elements, straight line forces and beams."

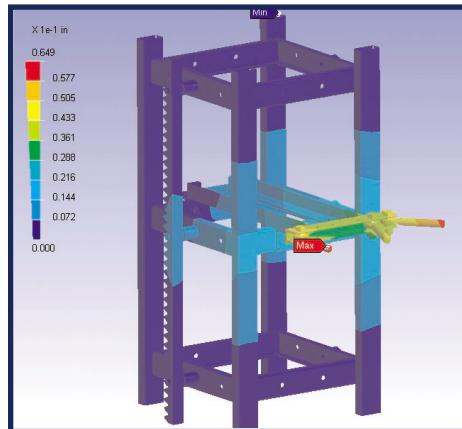

ANSYS DesignSpace screen image of the wall toes that link elevator car track to existing walls, Champion Elevators. This kind of analysis is performed on virtually every job done with Champion's products.

Oliver also likes the DesignSpace capability of displaying all materials used, the specifications of the steel, and dimensions of all the components. "We like the report generator and we use it a lot for due diligence," he noted. "First, we get a good solid model file, then we import it right into DesignSpace," he added. "We usually get dimensions and specifications that way."

Modeling is done in Champion's software for computer-aided design [EDS/Unigraphics

Corp.'s Solid Edge] but, again, without meshing. All of Champion's DesignSpace analyses are for static loading, not dynamic, and all are linear, not nonlinear.

### Design Specifics

Champion's design efforts focus on cutting weight and cost from its elevator cars. The goal was two-fold: to increase payloads and therefore customers' profits while cutting its own fabricating and shipping costs. Once the design is done, Meiresonne noted, the basic tower and elevator car structures do not change.

In addition, Champion redesigned its landing gates, the doors at the tops and bottoms of its elevator towers; the wall ties that attach the elevator towers to the customer's structure, and the elevator cars' fabricated steel feet.

The major re-engineering effort went into the structure of the elevator car to reduce its weight, simplify its manufacturing processes and cut costs. "But we ran into a few little problems," Meiresonne said, "which we worked out with DesignSpace."

One of the biggest of the challenges was not inside the car but underneath it, the buffers that ensure a safe, soft landing regardless of what might go wrong. For more than 20 years, Champion had relied on four coil springs formed from heavy steel rod, 3/4 inch or more in diameter. Over the years, the springs' prices kept going up. The car redesign replaced the four springs with two urethane shock absorber systems. They weigh less, cost less, and simplified manufacturing since only two buffer attachment points were needed rather than four spring pods.

“However, having just two contact points beneath the car rather than four doubled the stresses on the contact points,” Meiresonne pointed out. “And for various reasons, the new contact points were not beneath the cars’ centers of gravity. This created eccentric loadings. We used the ‘microanalysis’ capabilities of DesignSpace to redesign the car bottom with tapered trusses.”

“The maximum buffer loads which are experienced under conditions defined by the Elevator Safety Code were up to the yield points of the steel structurals that make up the underside of the elevator car floor,” Oliver recalled. The two buffers were offset toward the tower. This generated a cantilevered load that Champion did not have before. “Some redesigns of the trusses were required,” he said, “but in one case we just added a simple fish plate as a stiffener.”

A new landing gate door was designed not by engineers armed with computers and finite element software but by a long-time employee who did his calculations by hand. Billy McCoy, General Superintendent, created the design on his own initiative and showed it to Founder and President Walter Manning. Manning liked what he saw and the new design soon landed on Oliver’s desk for verification.

He tested it for load deformation. The applicable codes required the door panel to withstand a load of 1,125 pounds, deforming no more than 0.75 inch. DesignSpace and physical tests showed that Champion’s door panel would

deform no more than 0.3 inch, well within the standard’s allowable limits. Oliver also analyzed the new hinge mountings and frame supports.

A mundane steel fabrication is, in Oliver and Meiresonne’s view, the best illustration of DesignSpace use. It is the car “feet,” the forklift lifting point and test stand mounting, four to a car. “The redesign made them smaller and stronger,” Oliver said. “In fact, we got a much better safety factor so lighter steel could be used. We used DesignSpace to make sure the margins of safety were protected.

“We saved 45 pounds of steel per elevator car,” he added. While this might seem trivial, those 45 pounds no longer have to be hauled up and down the side of every Champion tower countless times.

## Benefits

“What we like about DesignSpace is that it works the way a design engineer works with materials, geometry and specifications,” Oliver said. “We use stresses from DesignSpace for safety factors. We use the report generator to print out all the steps taken and results generated whenever customers ask for it. We put in lots of comments into the reports, in a format not unlike PowerPoint, as to where we get the values we used in the modeling and calculations.”

Champion’s analysis needs are simplified by the fact that it buys its drives, braking systems and rack and driving pinion components. Suppliers

are responsible for those analyses, noted Oliver, adding, “we specify that they design in an eight-to-one safety margin for the racks and pinions.” Once assured these specifications have been met, Champion only has to analyze and verify the drive systems’ alignments and mountings.

The only concern with tower-mounted racks, he and Meiresonne observed, is precise alignment of tower components for smooth rides up and down. This is as much an on-site installation concern as one of fabricating in Houston. A jerky, bumpy or clattery ride will be rightly perceived as a poor installation or a bad design in the first place.

Having tightened up its manufacturing and shipping costs, privately held Champion is thriving. In contrast to most U.S. manufacturers, it is shipping systems to the low-manufacturing-cost countries on the Pacific Rim. An office in South Korea was opened in early in 2002.

Employment is 150, up from about 35 ten years ago. In the shorter term, construction — Champion’s core market — is to some extent recession resistant. Builders traditionally take advantage of low interest rates to build in advance of the economy’s inevitable recovery and upturn. Clearly, thanks to product redesign with DesignSpace, and to on-going analysis, Champion Elevators is ready.

[www.ansys.com](http://www.ansys.com)

ANSYS Inc.  
Southpointe  
275 Technology Drive  
Canonsburg, PA 15317  
U.S.A.

Toll-Free:  
1.866.ANSYS.AI (1.866.267.9724)

Toll-Free Mexico:  
001.866.ANSYS.AI

ANSYS is registered in the U.S. Patent and Trademark Office.  
©2003 SAS IP, Inc., a wholly owned subsidiary of ANSYS Inc.  
All Rights Reserved.

MCS0108JUNE03

[ansysinfo@ansys.com](mailto:ansysinfo@ansys.com)



NO 900 CERTIFICATION INCLUDES ALL COMMERCIAL PRODUCTS